

Checking voltage-frequency ratio on variable-speed drives with a Fluke ScopeMeter® 190 Series

Application Note

With their unique triggering and measuring functions, Fluke 190 Series ScopeMeters are ideal for analyzing the voltage-frequency ratio of pulse-width-modulated variable speed drives.

Variable-speed drives

Variable-speed drives (VSDs) provide a convenient and affordable method for varying the speed of robust ac motors. When connected to the mains, the rotation speed of an ac motor is directly related to the mains frequency and the number of poles of the motor, and traditionally an external gearbox was the only way to work with different speeds. This all changed with the introduction of high-power semiconductors which made it possible to build variable speed drives by electronically creating a supply voltage that operates at different frequencies. This has, however, created the need for new measurement capabilities which are provided by the Fluke 190 Series.

Pulse Width Modulation

AC drives using pulse width modulation (PWM) have found their way into many applications such as fans, pumps and conveyor belts driven by squirrel-cage asynchronous ac motors. These motors are robust and require little maintenance since they have no brushes that would need regular replacement.

The basic structure of a variable speed drive includes an input rectifier converting the mains voltage into a dc voltage that feeds the so-called dc-bus. This dc voltage is then converted into a 'variable frequency voltage' using electronic switches. Since the speed of the motor can be adjusted with a simple potentiometer or control signal from an external source, these drives have become a popular replacement for gearboxes.

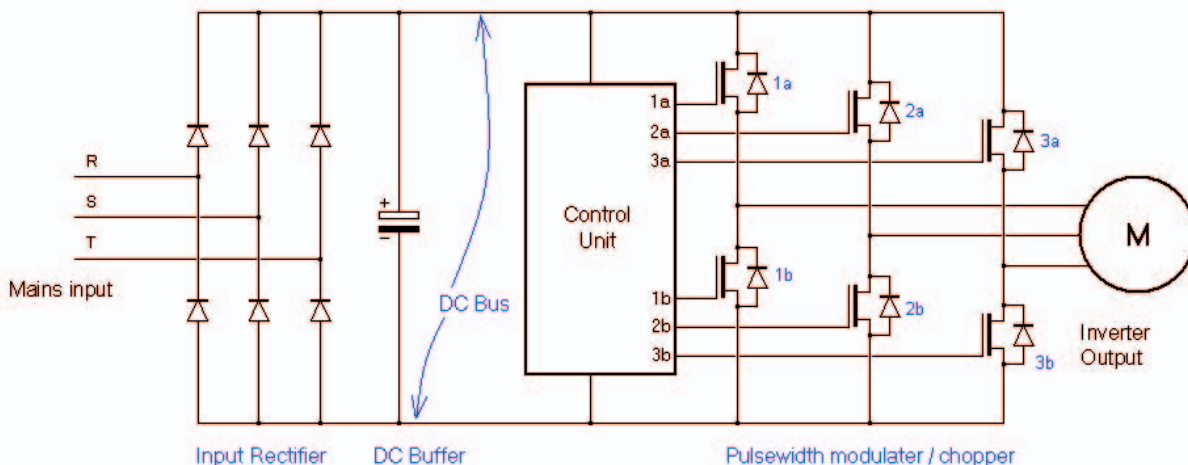

Figure 1: Basic structure of variable-speed drive.

The Motor

AC motors are designed for use with a rotating magnetic field of constant strength. The magnetic field is generated from the applied voltage and its strength is proportional to the V/Hz ratio. Normally the motor is designed to work with the local mains voltage (230 V/400 V or 120 V/208 V) and mains frequency (50 Hz or 60 Hz). The nominal values are shown on the motor type plate. When the motor is connected to a VSD, the drive unit changes the frequency of the output voltage, thereby changing the speed of the rotating magnetic field and thus the speed of the motor.

Lowering the frequency only, however, will generate a higher magnetic field since the V/Hz ratio increases. This will result in magnetic saturation which causes unstable running and generates higher temperatures in the motor. Likewise, increasing the frequency increases V/Hz ratio, reducing the magnetic field and resulting in lower torque.

To overcome these problems, the VSD also varies the voltage when the frequency is varied to maintain a constant V/Hz ratio. Preferably this is done over the complete working range of the VSD. The control type used in this case is called V/Hz control which in its simplest form takes a speed reference command from an external source and varies the voltage and frequency applied to the motor.

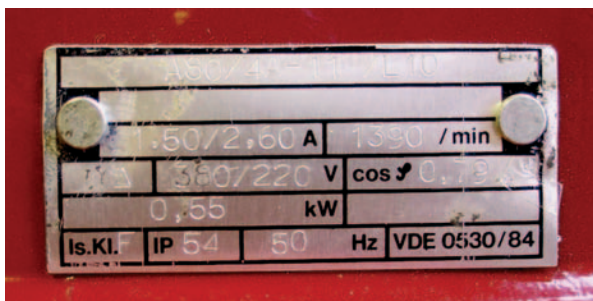

Figure 2: Motor type plate.

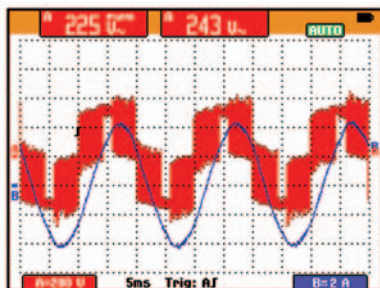

Figure 3: Measuring V_{pwm} and True rms Vac simultaneously. Amps signal is shown on input B.

Measurement requirements

To be able to verify if the V/Hz ratio is constant over the working range of the VSD, the output voltage and frequency of the drive must be measured simultaneously. The challenge here, however, is that the output waveform of a PWM drive is far from a sine wave, since it consists of pulses with varying width to create a motor drive current that resembles a sine wave. This is accomplished by varying the duty cycle of these pulses such that the current (but not the voltage) through the motor winding resembles a sine waveform.

In effect, the motor windings function as a low-pass filter through which the pulse-width modulated voltage causes a current resembling a sine wave to flow. A true rms voltmeter used in this situation would give erroneous readings since these meters give the rms voltage of the full bandwidth signal. This application, however, requires a

meter that is capable of measuring the effective voltage of the fundamental component only, since this is what the motor actually 'sees'. Another complication is that the complex modulated waveforms often make it difficult to obtain a stable picture and readings of the signal.

The Fluke 190B and 190C ScopeMeter Series, however, is ideal for this task since it features a special Vpwm function* that measures the voltage actually applied to motor whilst simultaneously measuring the frequency (Hz). The ScopeMeter also provides Connect-and-View™ triggering which automatically displays the stable picture.

Making measurements

The Fluke 190 Series ScopeMeter is certified up to a 1000 V CAT II and 600 V CAT III safety rating, making the series an extremely safe instrument for professional and industrial applications.

Connect the ScopeMeter directly to the motor terminals using the 10:1 VPS200 probe supplied as standard with the instrument. From the SCOPE READINGS menu select the readings V_{pwm} and Hz. The automatic triggering of the ScopeMeter assures a stable waveform and readings display, allowing measurements to be taken over the whole operating range of the drive unit.

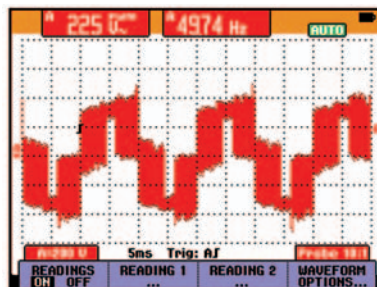

Figure 4: Measuring V_{pwm} and Hz.

Hz	V	V/Hz ratio
5.397	35	6.5
8.82	54	6.1
14.71	75	5.1
20.45	97	4.7
25.17	117	4.6
30.08	140	4.7
35.11	160	4.6
40.40	184	4.6
45.34	205	4.5
49.74	225	4.5
54.89	228	4.2
60.03	229	3.8
65.64	229	3.5
69.97	229	3.3
75.12	229	3.0

Figure 5: V - Hz measurement.

The measurements show that the V/Hz ratio is relatively constant over the working range for frequencies up to 50 Hz, where the voltage reaches the level of the input voltage of the drive. The readings match the nominal values for the motor, i.e. $220 \text{ V}/50 \text{ Hz} = 4.4$. When the frequency is increased above 50 Hz, the drive unit can no longer increase the output voltage since it is limited by the drive input of 230 V. This gives a lower V/Hz ratio resulting in a lower magnetic field and hence lower torque when running at high speed.

*Note: V_{pwm} is not available on models 192, 196 and 199.

When reducing the speed, the drive unit increases the V/Hz ratio slightly to improve the torque at lower speed. This technique is commonly referred to as Voltage Boost. Normally a motor gives less torque when running at lower speed, an effect known as 'Ohms loss'. This is caused by the resistance of the motor windings having greater influence on the total impedance of the windings at lower speed since the inductance of the windings decreases with frequency while the resistance remains constant. The part of the voltage that contributes to the inductance is consequently lower causing a relatively lower magnetic field at lower speeds.

Conclusion

The Fluke 190 Series ScopeMeter is particularly well suited for use during installation and service of variable-speed motor drives, showing the required readings and providing automatic triggering even on complex modulated drive output signals. The instrument makes analyzing V/Hz ratio easier than ever and makes it possible to analyze the behavior of the system and find possible causes for unstable motor behavior in the VSD configuration.

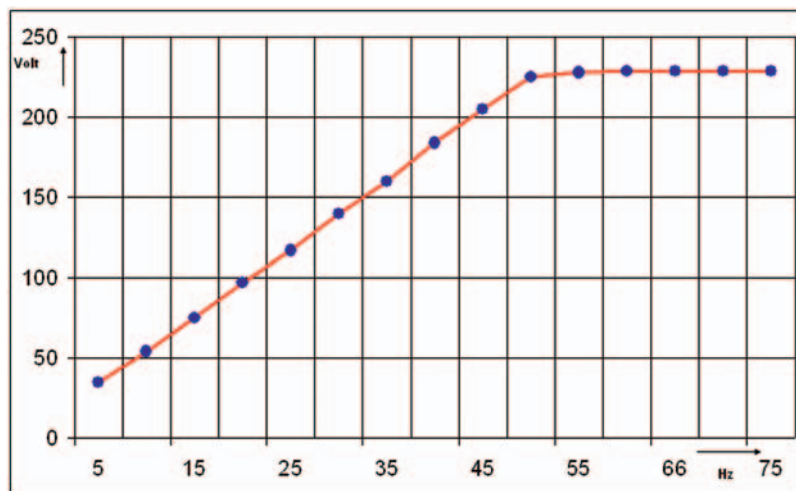

Figure 6: V - Hz graph.

Fluke. Keeping your world up and running.

Fluke Corporation
 PO Box 9090, Everett, WA USA 98206
 Fluke Europe B.V.
 PO Box 1186, 5602 BD Eindhoven, The Netherlands
 For more information call:
 In the U.S.A. (800) 443-5853 or Fax (425) 446-5116
 In Europe/M-East/Africa (31 40) 2 675 200 or Fax (31 40) 2 675 222
 In Canada (800) 36-FLUKE or Fax (905) 890-6866
 From other countries +1 (425) 446-5500 or Fax +1 (425) 446-5116
 Web access: <http://www.fluke.com>

©2005 Fluke Corporation. All rights reserved. Printed in U.S.A. 10/2005 2543364 A-EN-N Rev A